



The railborne Gialoader are electro-hydraulic driven loaders with a unique dual digging arm system designed to operate efficiently in narrow or limited work areas.

Technical features

- Hydraulic system powered by electric engine.
- The electro-hydraulic drive provides low installation and energy costs and maintains good air quality.
- A unique digging system loads the muck onto the conveyor, which then fills the haulage vehicle or Shuttlecar with a constant flow of muck.
- The dozer blades clean the sole effectively thus eliminating the need of manual clean up.
- The digging system can be used for lifting, scaling and track laying and can be repaired with standard sheet metal.
- The conveyor can be raised and lowered to suit the loading height of different haulage vehicles.
- Significantly reduces the number of niches needed.
- A built-in sprinkler system controls dust effectively.
- Suitable for use in drifts and tunnel with cross section from 8 m² and upwards.
- The Gialoader is operated from a standing position in a well protected compartment with a roof.
- The Gialoader is controlled by hydraulic joysticks.
- The chassis and conveyor are made of heavy duty plate joined together with continuous welds for maximum fatigue strength.
- The service brake is hydraulic. The Gialoader also has a spring applied hydraulic released parking and emergency brake.
- The Gialoader 8HR is suitable to combine with GIA:s HRST Shuttlecars. Available in 9 m³, 11,5 m³ and 14 m³ sizes.

Standard

CE mark according to European standards.

Options

- *Extended conveyor*
- *Drawbar for Shuttlecars*
- *Adjustable roof height*
- *Back-hoe digging system*
- *Cable reel*
Length and dimension of cable depends on the voltage chosen. Capacity 100 m at 400V.

Other options and dimensions on request.

Technical data

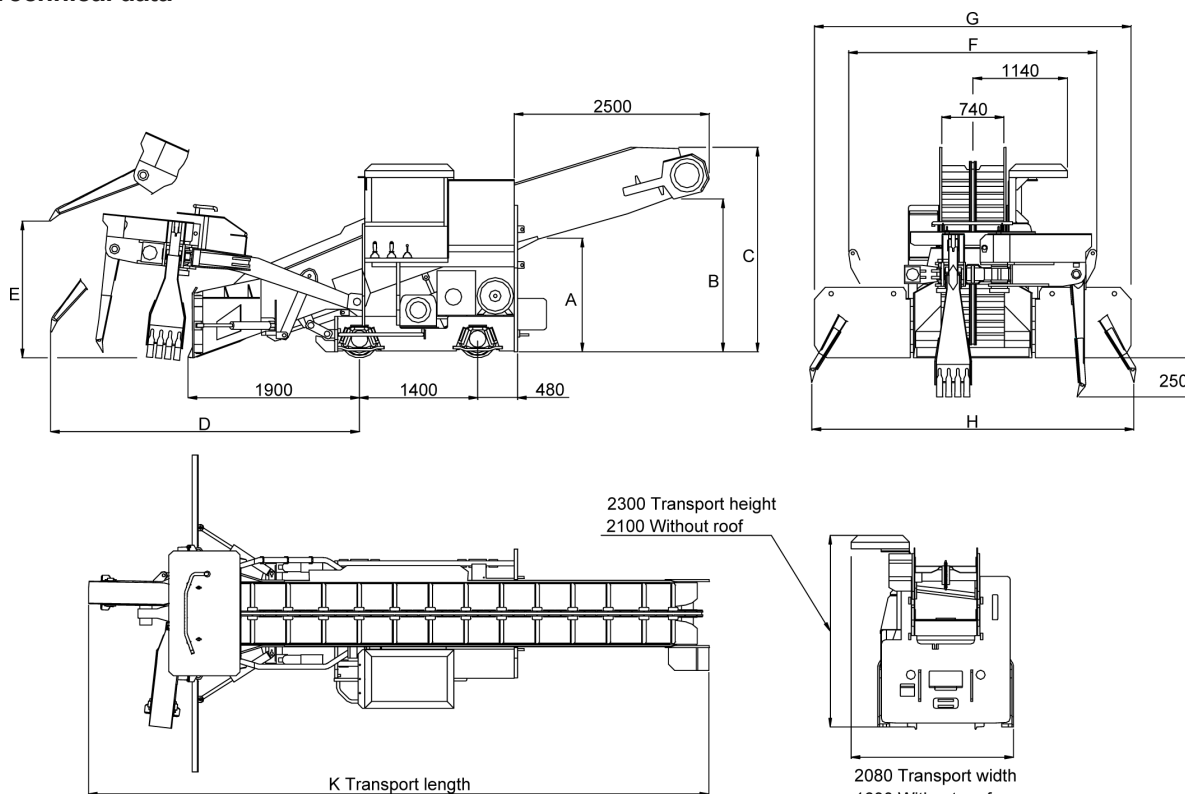

Standard electric system

Electrical motor	45 kW
Voltage	380 V 440 V
Lamps	6 x 70W

Transmission

Maximum travel speed

Electric	20 m/min
Towing speed (pony track)	maximum 15 km/h

Volume data-service

Hydraulic tank incl. cooler	130 dm ³
-----------------------------	---------------------

Functional data

Ground clearance	40 mm
Digging depth below ground level	250 mm
Max work gradient	1:25 (4%)
Loading capacity	approx. 3 m ³ /min
Digging width (H)	2 850, 3 400, 4 000 mm
Dozer blades (G)	2 550, 3 200, 3 800 mm
Track gauge	600, 750, 900, 914 mm
Min curv radius (towing)	12 m

Dimensions

A	Minimum 1 100 mm Maximum 1 500 mm
B	Minimum 1 500 mm Maximum 2 300 mm
C (Hight conveyor)	Minimum 2 200 mm Maximum 2 900 mm

Digging width	2 850	3 400	4 000
D (mm)	3 350	3 650	4 000
E (mm)	1 900	2 050	2 100
F (mm)	2 350	2 750	3 100
G (Dozer blades) (mm)	2 550	3 200	3 800
H (Digging width) (mm)	2 850	3 400	4 000
K (Transport length) (mm)	7 400	7 550	7 650
Weight (kg)	11 500	11 500	11 500

Dimensions during transport

Total length (K)	7 400, 7 550, 7 650 mm
Width	2 080 mm (without roof) 1 630 mm
Total hight	2 300 mm (without roof) 2 100 mm
Ground clearance	40 mm

Contact us for further information.

GIA - Grängesberg Industry AB
Kopparbergsvägen 37
SE-772 30 Grängesberg
Sweden

Phone +46 (0)73 421 9544
Email: contact@giaindstry.se
Web: www.giaindstry.se

Gialoader 8HR